

Solomon Practice Paper

Mechanics 1H

Time allowed: 90 minutes

Centre:

Name:

Teacher:

Question	Points	Score
1	6	
2	8	
3	9	
4	10	
5	11	
6	12	
7	19	
Total:	75	



1. Figure shows a light, inextensible string fixed at one end to a point P .

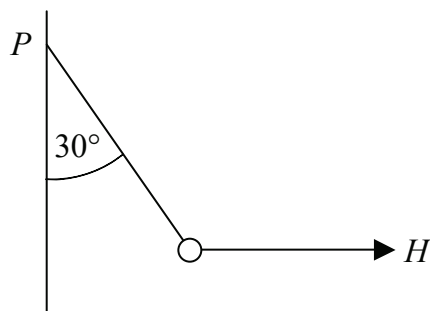

The other end is attached to a small object of weight 10N. The object is subjected to a horizontal force H so that the string makes an angle of 30° with the vertical.

- (a) Find the magnitude of the tension in the string. [3]
 (b) Show that the ratio of the magnitude of the tension to the magnitude of H is 2: 1. [3]

Total: 6

2. A particle of mass 8kg moves in a horizontal plane and is acted upon by three forces $F_1 = (5\mathbf{i} - 3\mathbf{j})\text{N}$, $F_2 = (3\mathbf{i} + 2\mathbf{j})\text{N}$ and $F_3 = (4\mathbf{i} - 5\mathbf{j})\text{N}$, where \mathbf{i} and \mathbf{j} are perpendicular horizontal unit vectors.

- (a) Find the magnitude, in newtons, of the resultant force which acts on the particle, giving your answer in the form $k\sqrt{5}$. [4]
 (b) Calculate, giving your answer in degrees correct to 1 decimal place, the angle the acceleration of the particle makes with the vector \mathbf{i} . [4]

Total: 8

3. A lorry accelerates uniformly from 5 ms^{-1} to 20 ms^{-1} in 30 seconds.

- (a) Find how far it travels while accelerating. [3]
 (b) Find, in seconds correct to 2 decimal places, the length of time it takes for the lorry to cover the first half of this distance. [6]

Total: 9

4. In this question, \mathbf{i} and \mathbf{j} are perpendicular horizontal unit vectors and O is a fixed origin. A pedestrian moves with constant velocity $[(22q - 3)\mathbf{i} + (q + 2)\mathbf{j}] \text{ ms}^{-1}$.

Given that the velocity of the pedestrian is parallel to the vector $(\mathbf{i} - \mathbf{j})$,

- (a) Show that one possible value of q is -1 and find the other possible value of q . [4]

Given that $q = -1$, and that the pedestrian started walking at the point with position vector $(6\mathbf{i} - \mathbf{j})\text{m}$,

- (b) find the length of time for which the pedestrian is less than 5m from O . [6]

Total: 10

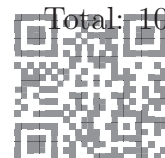

5. A sledgehammer of mass 12kg is being used to drive a wooden post of mass 4kg into the ground. A labourer moves the sledgehammer from rest at a point 0.5m vertically above the post with constant acceleration 16 ms^{-2} directed towards the post.

(a) Find the velocity with which the sledgehammer hits the post. [3]

When the sledgehammer hits the post, they both move together with common speed, V .

(b) Show that $V = 3 \text{ ms}^{-1}$. [2]

As the sledgehammer hits the post, the labourer relaxes his grip and applies no further force. The sledgehammer and post are brought to rest by the action of a resistive force from the ground of magnitude 1500N.

(c) Find, in centimetres, the total distance that the sledgehammer and the post travel together before coming to rest. [6]

Total: 11

6. Figure shows a picnic bench of mass 20kg which consists of a horizontal plank of wood of length 2m resting on two supports, each of which is 0.6m from the centre of the plank.

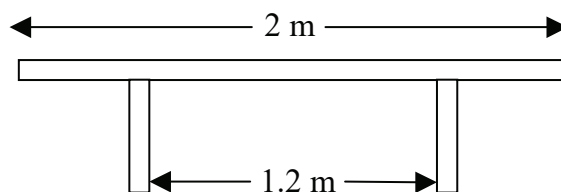

Luigi sits on the bench at its midpoint and his mother Maria sits at one end. Their masses are 40kg and 75kg respectively.

By modelling the bench as a uniform rod and Luigi and Maria as particles,

(a) find the reaction at each of the two supports. [6]

Luigi moves to sit closer to his mother.

(b) Find how close Luigi can get to his mother before the reaction at one of the supports becomes zero. [5]

(c) Explain the significance of a zero reaction at one of the supports. [1]

Total: 12

7. Figure shows a particle of mass 4kg resting on the surface of a rough plane inclined at an angle of 30° to the horizontal.

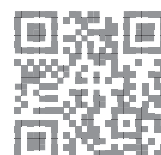

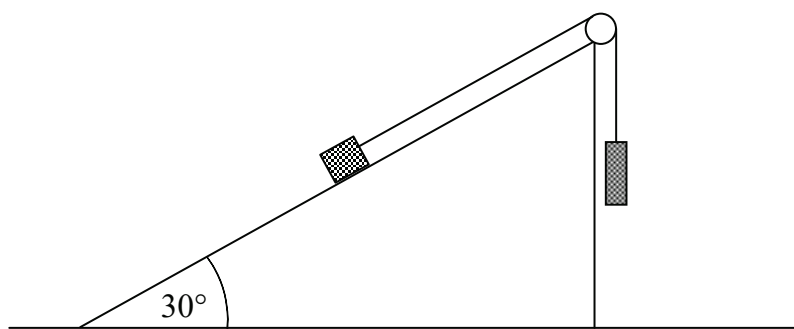

It is connected by a light inextensible string passing over a smooth pulley at the top of the plane, to a particle of mass 5kg which hangs freely.

The coefficient of friction between the 4kg mass and the plane is μ and when the system is released from rest the 4kg mass starts to move up the slope.

(a) Show that the acceleration of the system is $\frac{1}{9}(3 - 2\mu\sqrt{3})g \text{ ms}^{-2}$. [7]

(b) Hence, find the maximum value of μ . [3]

Given that $\mu = \frac{1}{2}$,

(c) find the tension in the string in terms of g , [4]

(d) show that the magnitude of the force on the pulley is given by $\frac{5}{3}(2\sqrt{3} + 1)g \text{ N}$. [5]

Total: 19

