

1

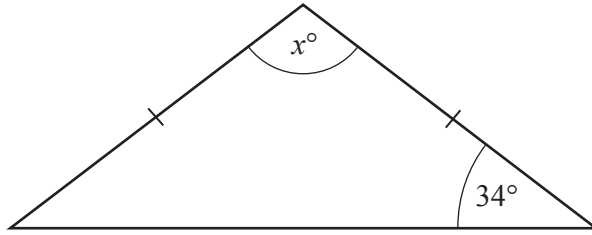

NOT TO SCALE

The diagram shows an isosceles triangle.

Find the value of x .

$x = \dots\dots\dots$ [2]

2 Simplify.

$$y \times 27 - y \times 77$$

$\dots\dots\dots$ [1]

3 Find the sum of 3^2 and -3^2 .

$\dots\dots\dots$ [1]

4 Expand.

$$x(3 + x^2)$$

$\dots\dots\dots$ [2]



- 5 Jenna buys 2.4 m of ribbon and 4.8 m of fabric.
 The total cost is \$33.48 .
 Ribbon costs \$0.85 per metre.

Find the cost of 1 m of fabric.

\$ [3]

- 6 (a) These are the first five terms of a sequence.

27 26 23 18 11

Find the next two terms in the sequence.

....., [2]

- (b) The table shows information about two different sequences.

	First five terms of sequence	n th term
Sequence A	3 10 17 24 31	
Sequence B	2 11 26 47 74	

Complete the table.

[4]



7 Without using a calculator, work out $\frac{5}{9} - \frac{1}{6}$.

You must show all your working and give your answer as a fraction in its simplest form.

..... [2]

8 Daryl records the number of hours in a week 8 people spend exercising.

5 2 1.5 3 18 4.5 2 4

(a) Find the median.

..... h [2]

(b) Explain why the mean may not be a suitable average to use.

..... [1]

9 The diagram shows three triangles A, B and C.

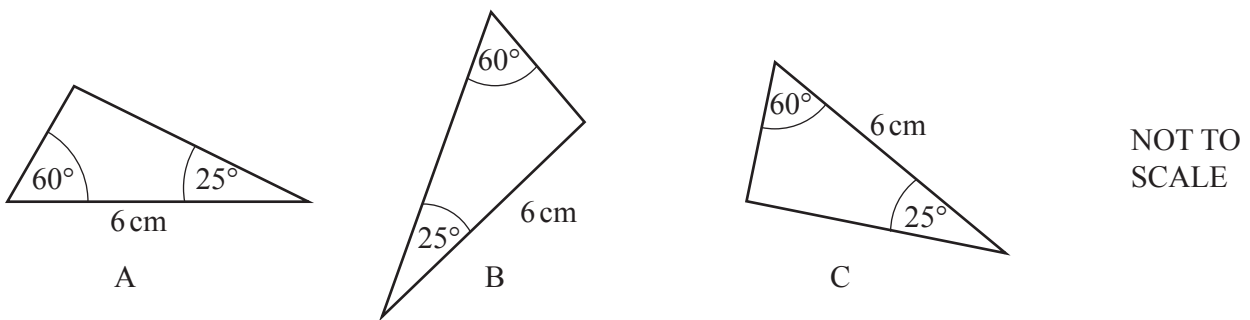

(a) Which two of the triangles A, B and C are congruent with each other?

..... [1]

(b) Draw a ring around the congruence criterion that can be used to support your answer to part (a).

SSS ASA SAS RHS

[1]

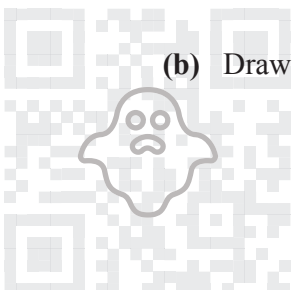

10 Calculate.

(a) 2000×1.2^3

..... [1]

(b) $2\frac{1}{8} \times \frac{6}{17}$

..... [1]

(c) $\frac{4.5(\cos 30^\circ)}{\sqrt{3}} - 2$

..... [1]

11 The graph of $y = (x - 3)(x + b)(x + 2)$ intersects the y -axis at -30 .

(a) Find the value of b .

$b =$ [2]

(b) When $x > 0$ the graph crosses the x -axis once.

Write down the coordinates of this point.

(..... ,) [1]

12 $x = 3^2 \times 5^2 \times 7 \times 199^{57}$ when written as a product of its prime factors.

Write $x \div 315$ as a product of its prime factors.

..... [2]



13 The table shows information about the mass of each of 50 children.

Mass (k kg)	Cumulative Frequency
$k \leq 20$	0
$k \leq 22$	7
$k \leq 24$	23
$k \leq 28$	35
$k \leq 32$	43
$k \leq 36$	47
$k \leq 42$	50

(a) Draw a cumulative frequency diagram to show this information.

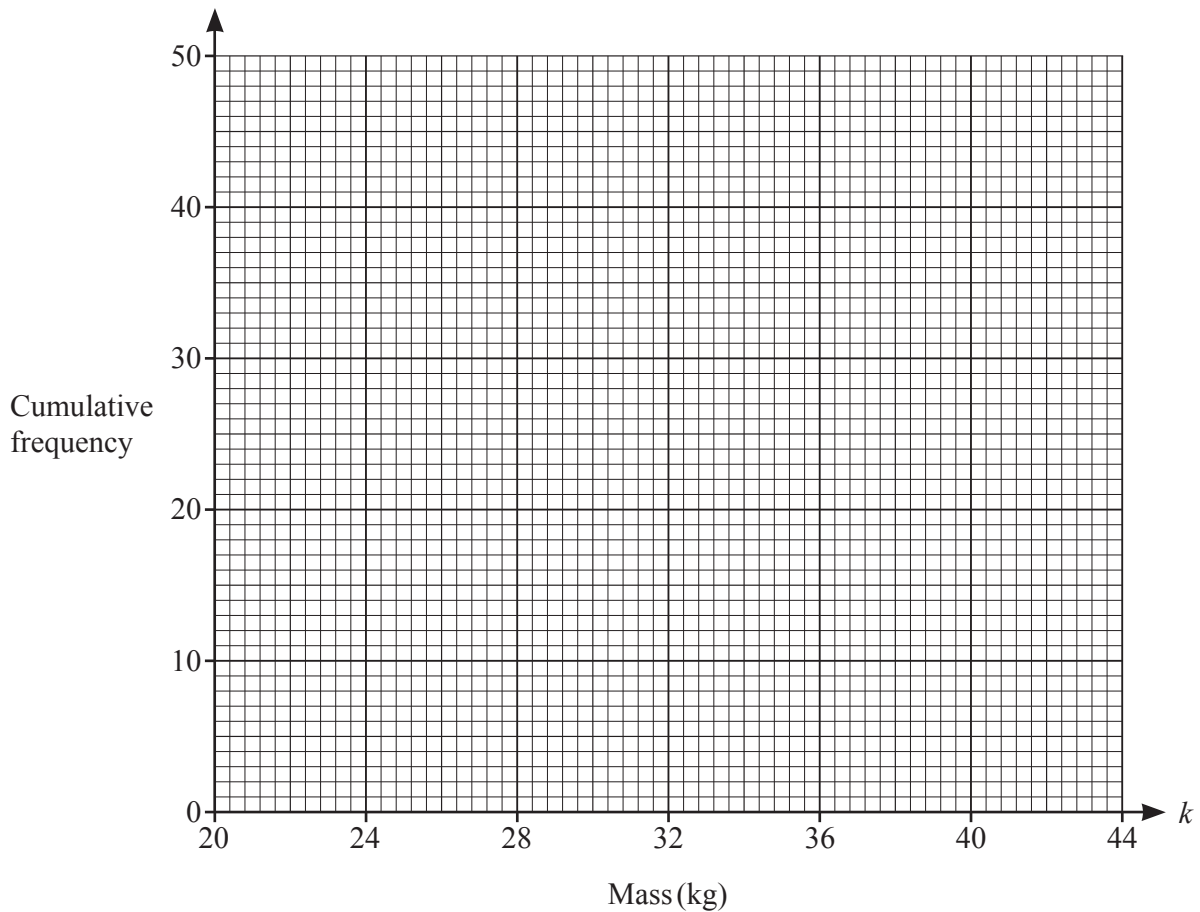

[3]

(b) Use your graph to find an estimate of the 90th percentile.

..... [1]



- 14 136 girls and 144 boys each measure the distance they jump in centimetres. The box-and-whisker plots show the distributions of these distances.

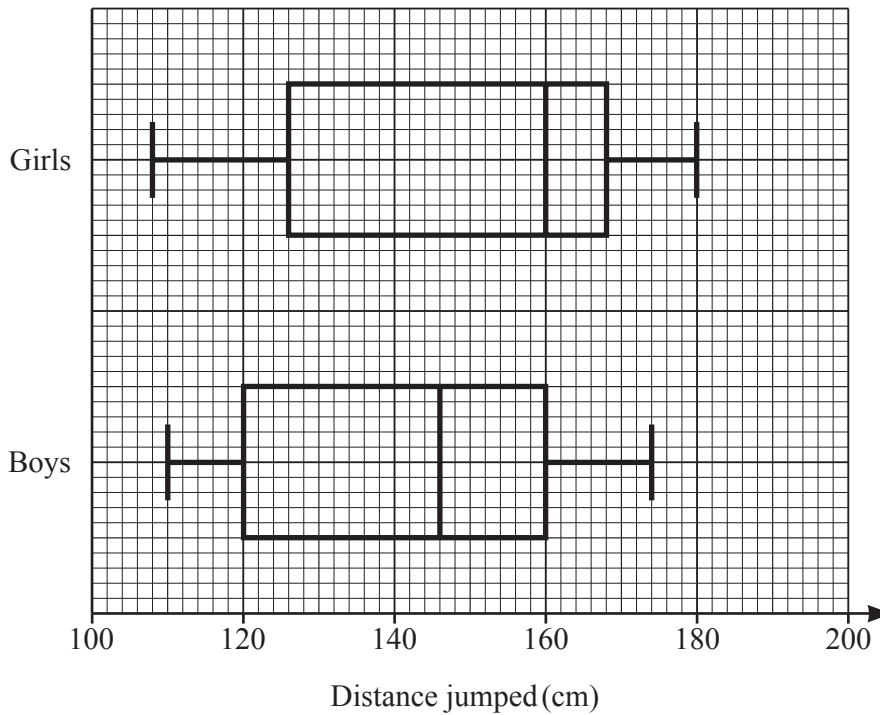

Each child who jumps a distance greater than 160 cm gets a certificate.

Work out an estimate of the total number of children who get a certificate.

..... [2]

- 15

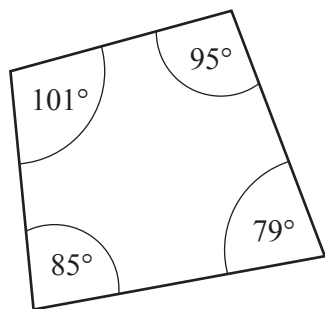

NOT TO SCALE

The diagram shows a quadrilateral.

Give a geometrical reason why this is a cyclic quadrilateral.

..... [1]



16 (a) Shade the region indicated in each Venn diagram.

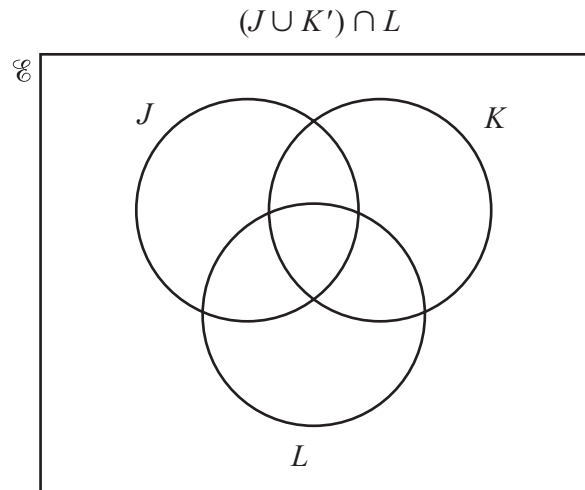
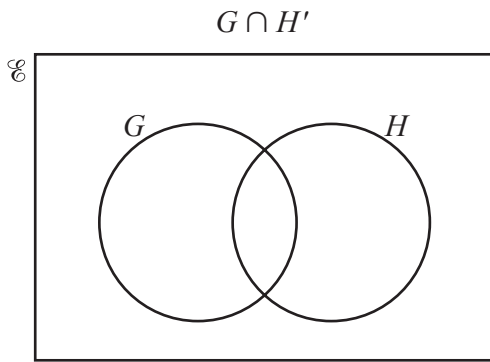

[2]

(b) The Venn diagram shows some information about the number of elements in sets A , B , C and \mathcal{U} .

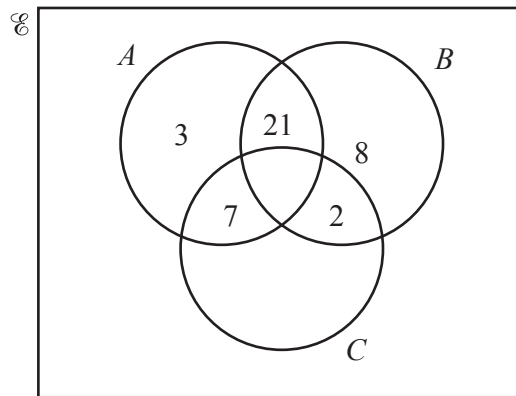

Given the following information, complete the Venn diagram.

$$\begin{aligned} n(A \cap B \cap C) &= 1 \\ n(A \cup B \cup C)' &= 17 \\ n(C) &= 42 \end{aligned}$$

[2]



17

$$f(x) = x^2$$

$$g(x) = \frac{x+5}{2}$$

$$h(x) = 7x - 3$$

(a) Find $f(-3)$.

..... [1]

(b) Find $g^{-1}(x)$.

$g^{-1}(x) =$ [2]

(c) Solve $gf(x) = hh^{-1}(63)$ where $x > 0$.

$x =$ [3]



- 18 Write $0.4\dot{1}\dot{9}$ as a fraction in its simplest form.
You must show all your working.

..... [3]

- 19 Katy picks a number at random from the numbers 2, 3 and 5.
She then picks a number at random from the numbers 5, 6, 7 and 9.
When she adds the two numbers the answer is even.

Find the probability that **exactly one** of the numbers picked is a 5.

..... [3]



20 Simplify fully.

(a) $(81x^{16})^{\frac{3}{4}}$

..... [2]

(b) $\left(\frac{1}{y^2}\right)^{-\frac{1}{2}}$

..... [1]

21

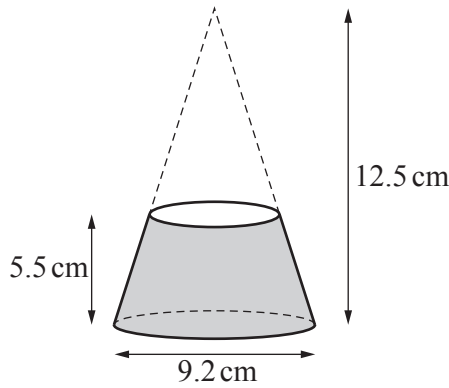

NOT TO SCALE

A solid is made by cutting a small cone from a larger cone, as shown in the diagram.
 The height of the larger cone is 12.5 cm.
 The height of the solid is 5.5 cm.
 The diameter of the base of the larger cone is 9.2 cm.

Work out the volume of the solid.

[The volume, V , of a cone with radius r and height h is $V = \frac{1}{3}\pi r^2 h$.]

..... cm³ [4]

Questions 22 and 23 are printed on the next page.



- 22 The volumes of two mathematically similar objects are 56 cm^3 and 875 cm^3 .
The height of the smaller object is 18 cm.

Find the height of the larger object.

..... cm [3]

- 23 Solve $\frac{4}{x+1} + \frac{2}{2x-5} = 3$.

You must show all your working.

$x = \dots\dots\dots$ or $x = \dots\dots\dots$ [7]

