

1 (a) The list shows 15 midday temperatures, in degrees Celsius, in Suntown.

17 21 21 18 23 22 25 19
 21 17 19 18 21 24 23

(i) Complete the stem-and-leaf diagram to show this information.

1	7
2	

Key: 1|7 represents 17°C

[2]

(ii) Find the median.

..... °C [1]

(iii) Find the upper quartile.

..... °C [1]

(iv) Rahul draws a pie chart to show this information.

Calculate the sector angle for the number of days the temperature is 18°C.

..... [2]

(b)

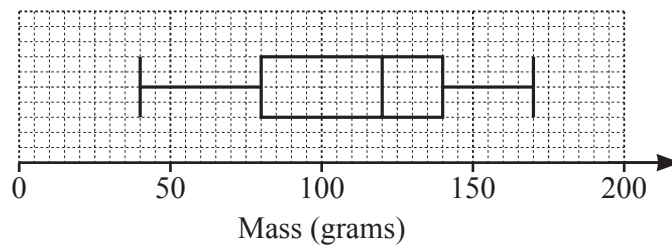

The box-and-whisker plot shows information about the masses, in grams, of some apples.

(i) Find the median.

..... g [1]

(ii) Find the range.

..... g [1]

(iii) Find the interquartile range.

..... g [1]



- (c) (i) The time, t minutes, spent on homework in one week by each of 200 students is recorded. The table shows the results.

Time (t minutes)	$40 < t \leq 60$	$60 < t \leq 80$	$80 < t \leq 90$	$90 < t \leq 100$	$100 < t \leq 150$
Frequency	6	10	70	84	30

Calculate an estimate of the mean.

..... min [4]

- (ii) A new table with different class intervals is completed.

Time (t minutes)	$40 < t \leq 90$	$90 < t \leq 150$
Frequency	86	114

On a histogram the height of the bar for the $40 < t \leq 90$ interval is 17.2 cm.

Calculate the height of the bar for the $90 < t \leq 150$ interval.

..... cm [2]



- 2 (a) Alex, Bobbie and Chris share strawberries in the ratio Alex : Bobbie : Chris = 3 : 2 : 2.
Chris receives 12 strawberries.

Calculate the total number of strawberries shared.

..... [2]

- (b) In a sale, a shop reduces all prices by 12%.

- (i) Dina buys a book which has an original price of \$6.50 .

Calculate how much Dina pays for the book.

\$ [2]

- (ii) Elu pays \$11 for a toy.

Calculate the original price of the toy.

\$ [2]

- (c) Feri invests some money.

The rate of interest for the first year is 2.5%.

At the end of the second year the overall percentage increase of Feri's investment is 6.6%.

Find the rate of interest for the second year.

..... % [2]



(d) A radioactive substance decays at an exponential rate of 2% per day.
The initial mass is 80 g.

(i) Find the mass at the end of 5 days.

..... g [2]

(ii) Find how many **more** whole days, after day 5, it takes for the mass to reduce to less than 67 g.

..... [3]



3 (a) Geeta buys x apples, $(x + 7)$ oranges and $(2x - 1)$ bananas.
The total number of pieces of fruit Geeta buys is 30.

(i) Find the number of apples Geeta buys.

..... [3]

(ii) The cost of one apple is 15 cents.
The cost of one orange is 18 cents.
The total cost of all the fruit is \$5.55 .

Find the cost, in cents, of one banana.

..... cents [3]

(b) (i) Solve.

$$\frac{3w}{16} - 1 = \frac{1}{2}$$

$w =$ [2]

(ii)
$$\frac{3(2^{-y})}{16} - 1 = \frac{1}{2}$$

Find the value of y .

$y =$ [2]



(c) (i) Solve the simultaneous equations.

$$2p + q = 2$$

$$p - q = -\frac{1}{2}$$

$$p = \dots\dots\dots$$

$$q = \dots\dots\dots [2]$$

(ii) Hence, for $0^\circ \leq u \leq 360^\circ$ and $0^\circ \leq v \leq 360^\circ$, solve the simultaneous equations.

$$2 \sin u + \cos v = 2$$

$$\sin u - \cos v = -\frac{1}{2}$$

$$u = \dots\dots\dots \text{ or } u = \dots\dots\dots$$

$$v = \dots\dots\dots \text{ or } v = \dots\dots\dots [4]$$



4 $f(x) = 2x - 1$ $g(x) = 3x - 2$ $h(x) = \frac{1}{x}, x \neq 0$ $j(x) = 5^x$

(a) Find

(i) $f(2)$,

..... [1]

(ii) $gf(2)$.

..... [1]

(b) Find $g^{-1}(x)$.

$g^{-1}(x) =$ [2]

(c) Find x when $h(x) = j(-2)$.

$x =$ [2]

(d) Write $f(x) - h(x)$ as a single fraction.

..... [2]



(e) Find the value of $jj(2)$.

..... [1]

(f) Find x when $j^{-1}(x) = 4$.

$x =$ [2]



- 5 (a) $ABCDEFGH$ is a regular octagon with sides of length 6 cm. The diagram shows part of the octagon. O is the centre of the octagon and M is the midpoint of AB .

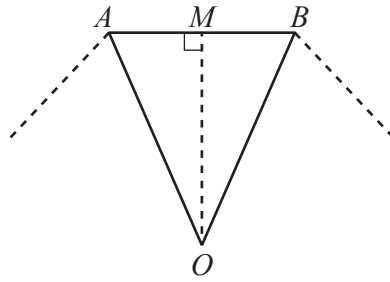

NOT TO SCALE

- (i) (a) Show that angle OAM is 67.5° .

[2]

- (b) Calculate the area of the octagon.

..... cm^2 [4]

- (ii) Find the area of the circle that passes through the vertices of the octagon.

..... cm^2 [3]



(b)

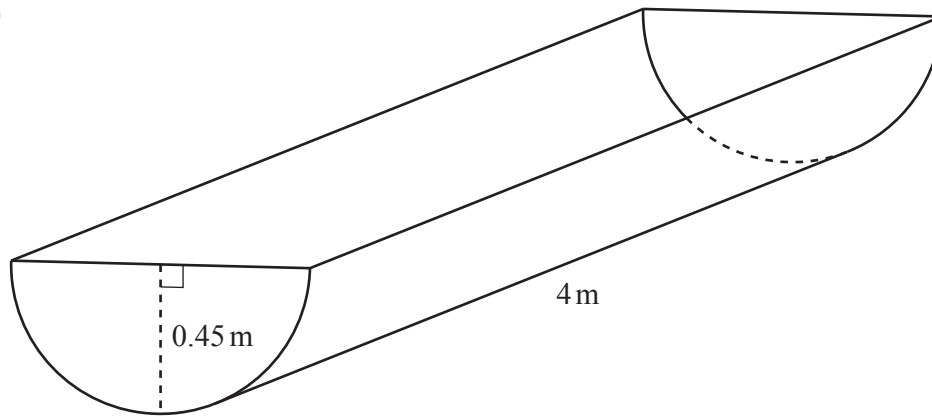

NOT TO SCALE

The diagram shows a horizontal container for water with a uniform cross-section. The cross-section is a semicircle. The radius of the semicircle is 0.45 m and the length of the container is 4 m.

(i) Calculate the volume of the container.

..... m³ [2]

(ii)

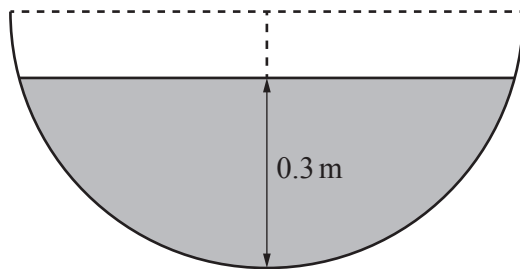

NOT TO SCALE

The greatest depth of the water in the container is 0.3 m. The diagram shows the cross-section.

Calculate the number of litres of water in the container. Give your answer correct to the nearest integer.

..... litres [6]



6 (a)

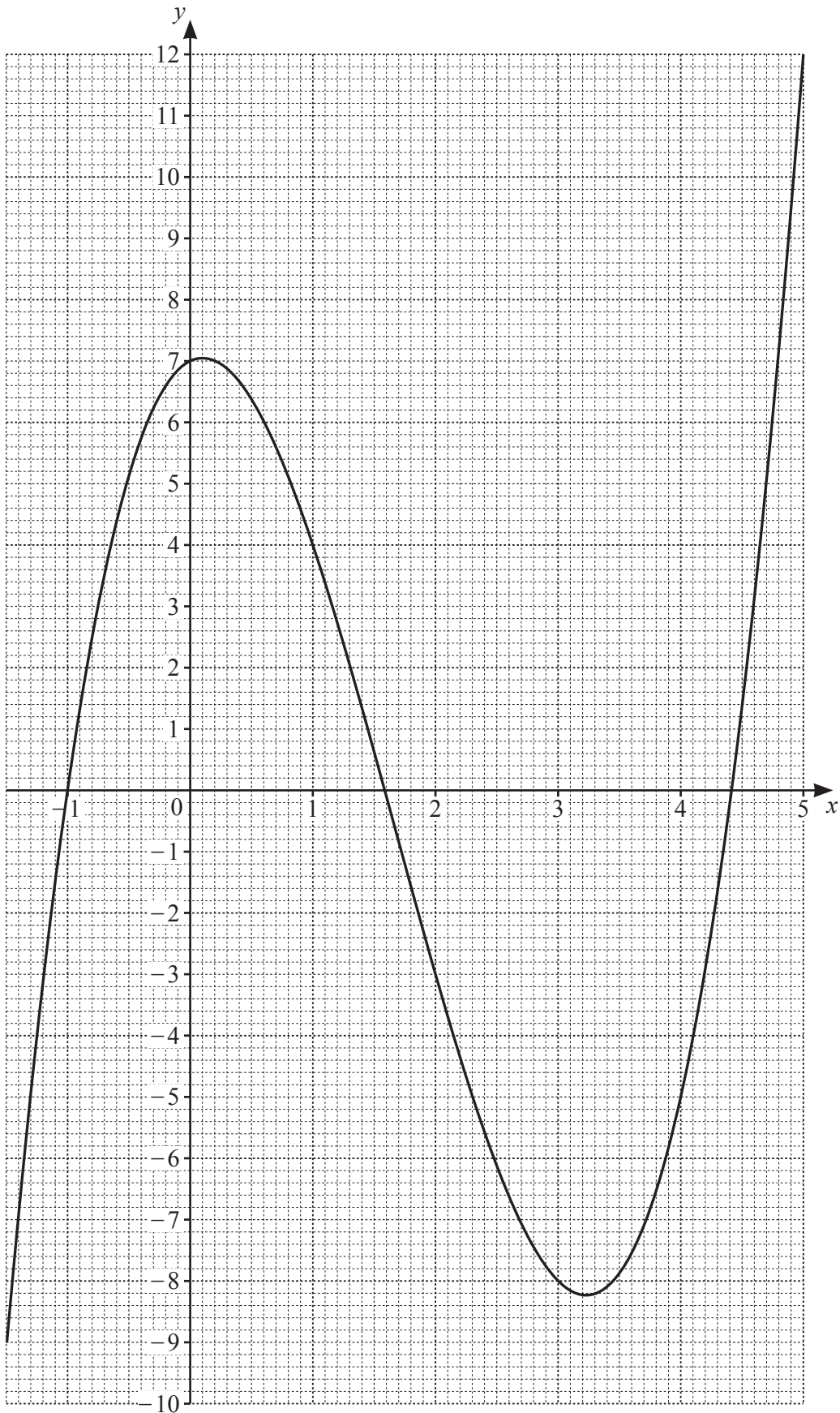

The diagram shows the graph of $y = f(x)$ for $-1.5 \leq x \leq 5$.

(i) Find $f(2)$.

..... [1]

(ii) Solve the equation $f(x) = 0$ for $-1.5 \leq x \leq 5$.

$x = \dots\dots\dots$ or $x = \dots\dots\dots$ or $x = \dots\dots\dots$ [3]

(iii) $f(x) = k$ has three solutions for $-1.5 \leq x \leq 5$ where k is an integer.

Find the smallest possible value of k .

$k = \dots\dots\dots$ [1]

(iv) On the grid, draw a line $y = mx$ so that $f(x) = mx$ has exactly one solution for $-1.5 \leq x \leq 5$. [2]

(b) $y = 3x^2 - 12x + 7$

(i) Find the value of $\frac{dy}{dx}$ when $x = 5$.

..... [3]

(ii) Find the coordinates of the point on the graph of $y = 3x^2 - 12x + 7$ where the gradient is 0.

(..... ,) [2]

(c) When $y = 2x^p + qx^2$, $\frac{dy}{dx} = 14x^6 + 6x$.

Find the value of p and the value of q .

$p = \dots\dots\dots$

$q = \dots\dots\dots$ [2]



7

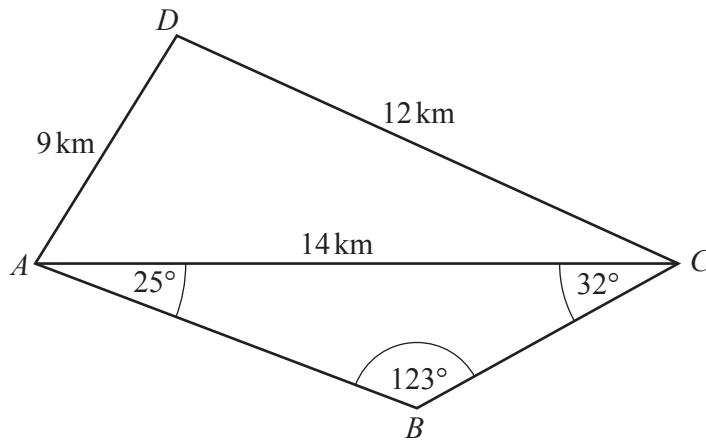

NOT TO SCALE

(a) Calculate angle ACD .

Angle $ACD = \dots\dots\dots$ [4]

(b) Show that $BC = 7.05$ km, correct to 2 decimal places.

[3]



(c) Calculate the shortest distance from B to AC .

..... km [3]

(d) Calculate the length of the straight line BD .

$BD =$ km [4]

(e) C is due east of A .

Find the bearing of D from C .

..... [2]



- 8 (a) (i) Use set notation to describe the shaded region in the Venn diagram.

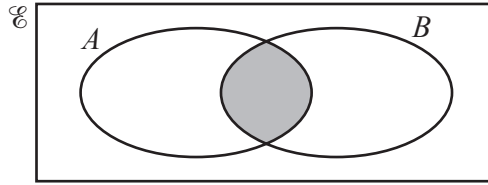

..... [1]

- (ii) Shade the correct region in each Venn diagram.

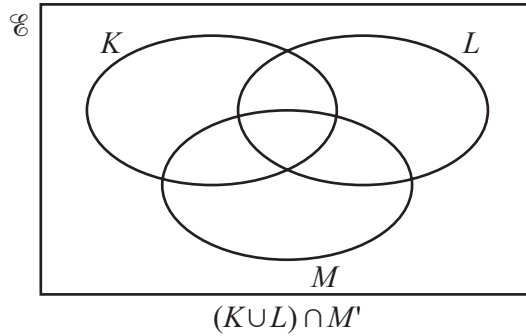
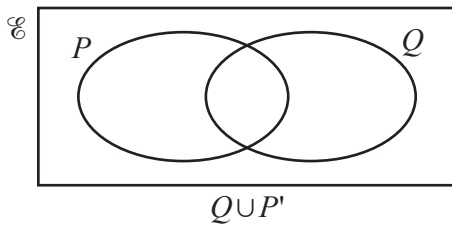

[2]

- (b)



The diagram shows 11 cards.

- (i) One of these cards is chosen at random.

Write down the probability that the letter on the card is **not** A.

..... [1]

- (ii) A card is chosen at random from these 11 cards and then replaced. A second card is then chosen at random.

Find the probability that exactly one card has the letter N.

..... [3]



(c)

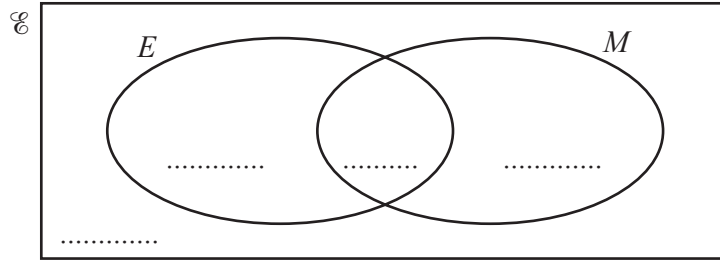

50 students are asked if they like English (E) and if they like mathematics (M).
 3 say they do not like English and do not like mathematics.
 33 say they like English.
 42 say they like mathematics.

(i) Complete the Venn diagram. [2]

(ii) A student is chosen at random.

Find the probability that this student likes English and likes mathematics.

..... [1]

(iii) Two students are chosen at random.

Find the probability that they both like mathematics.

..... [2]

(iv) Two students who like English are chosen at random.

Find the probability that they both also like mathematics.

..... [2]

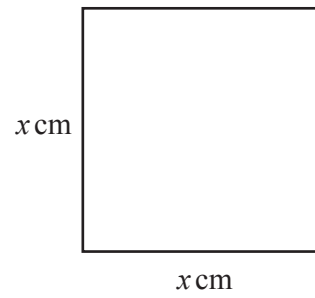
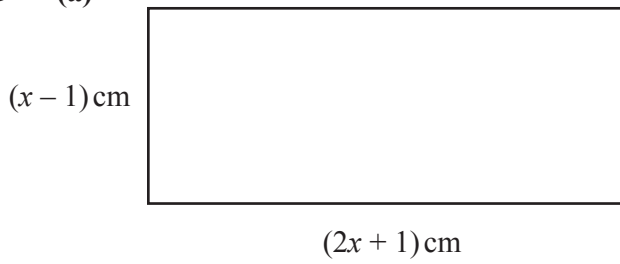

9 (a)

NOT TO
SCALE

The area of the rectangle is 29 cm^2 greater than the area of the square.
The difference between the perimeters of the two shapes is $k \text{ cm}$.

Find the value of k .
You must show all your working.

$$k = \dots\dots\dots [6]$$



(b)

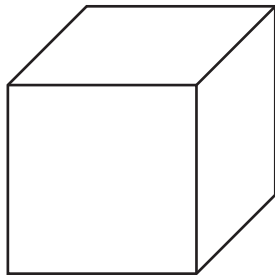

$(y + 1)$ cm

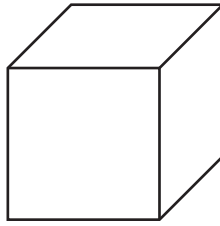

y cm

NOT TO
SCALE

The volume of the larger cube is 5 cm^3 greater than the volume of the smaller cube.

(i) Show that $3y^2 + 3y - 4 = 0$.

[4]

(ii) Find the volume of the smaller cube.
Show all your working and give your answer correct to 2 decimal places.

..... cm^3 [4]

